

CONDUIT ID RANGE	APPLICABLE 1.25" [32mm] CONDUIT
1.156" - 1.510" [26.36mm - 38.35mm]	PVC SCH 40 PVC SCH 80 EMT HDPE SCH 40 HDPE SCH 80 HDPE SDR 11 HDPE SDR 13.5 HDPE SDR 15.5 HDPE SDR 9

Applicable conduit types based on product's conduit ID range meeting or exceeding conduit ID dimensions specified in one or more of following standards: UL651, UL651A, ASTM F2160, NEMA TC 6 & 8

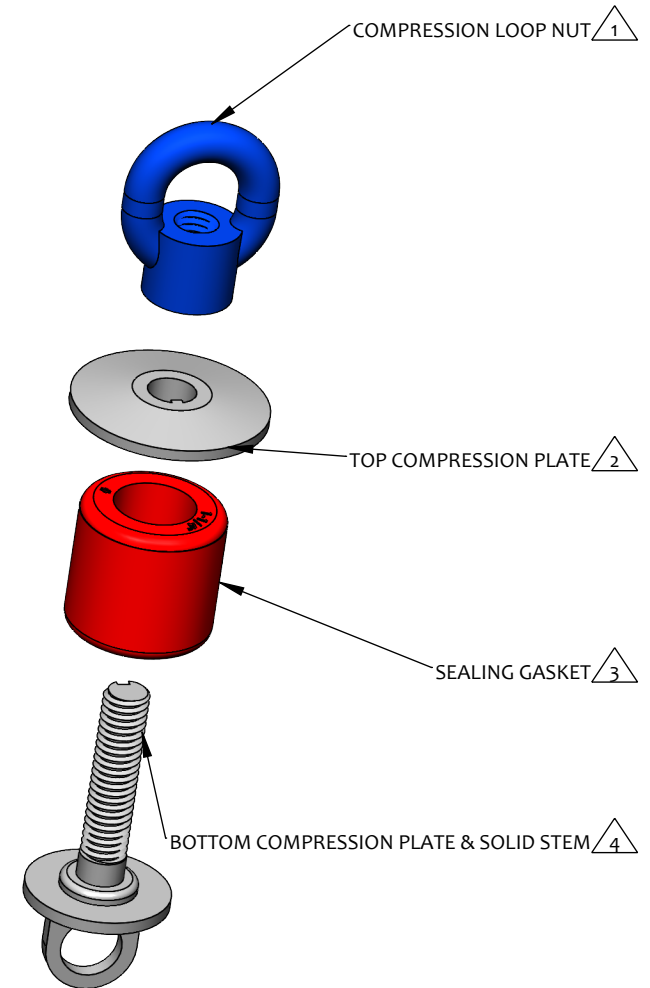
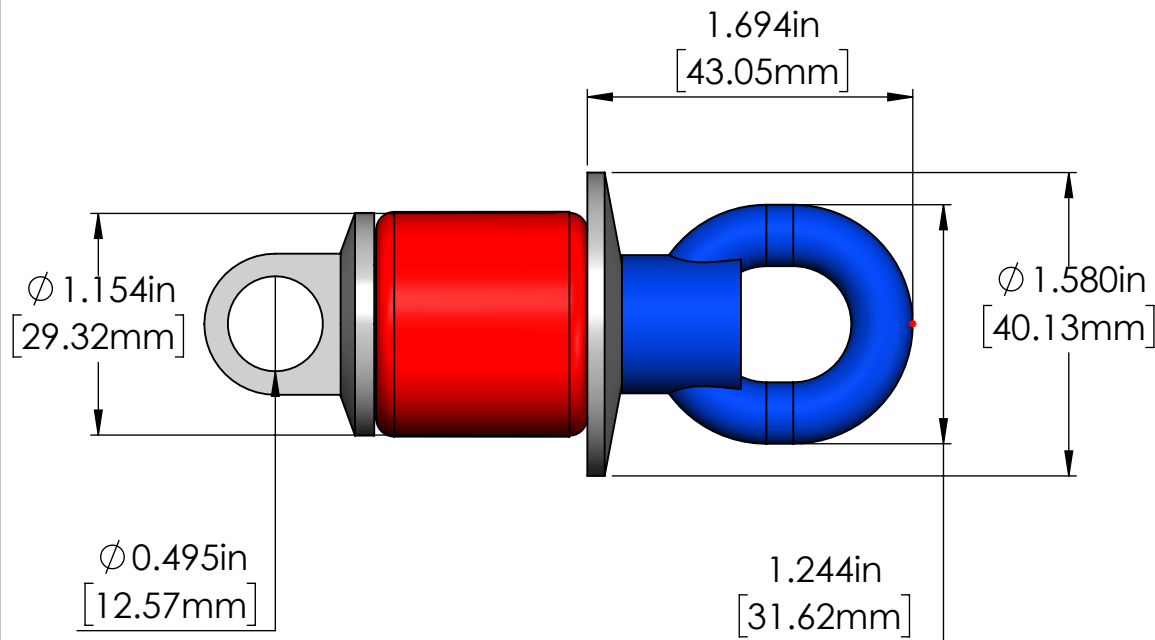

Kwikie™
Blank Duct Plugs

NOTES:

- 1 Material: PVC
- 2 Material: Polypropylene
- 3 Material: Thermoplastic Elastomer
- 4 Material: Nylon

TITLE	BLANK DUCT PLUG, LOOP NUT, 1.25" 32mm		
PROPRIETARY AND CONFIDENTIAL THE INFORMATION CONTAINED IN THIS DRAWING IS THE SOLE PROPERTY OF CAL AM MANUFACTURING. ANY REPRODUCTION IN PART OR AS A WHOLE WITHOUT THE WRITTEN PERMISSION OF CAL AM MANUFACTURING IS PROHIBITED.	DRAWN	J.C. MORENO	DATE: 06-26-2023
	DRAWING NO.	KWI-5120-12	UNLESS OTHERWISE SPECIFIED DIMENSIONS ARE IN INCHES TOLERANCES: X±0.1 X.X±0.05 X.XX±0.030 X.XXX±0.020
	REVISION	B	
	SCALE:	1:2	PRODUCT NUMBER:



SHEET 1 OF 1