

KEY FEATURES

- Flexible rubber cones are durable for many repeated uses
- Fast and efficient for long runs
- Easy pull-back
- Ultra tough and tear resistant

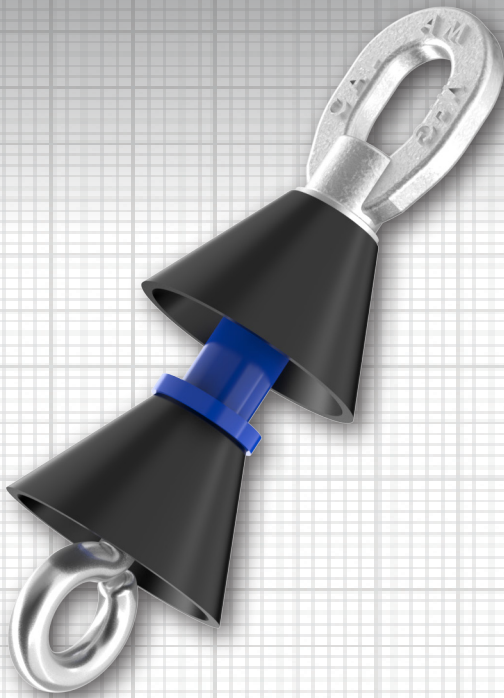

Duct Cone Projectile

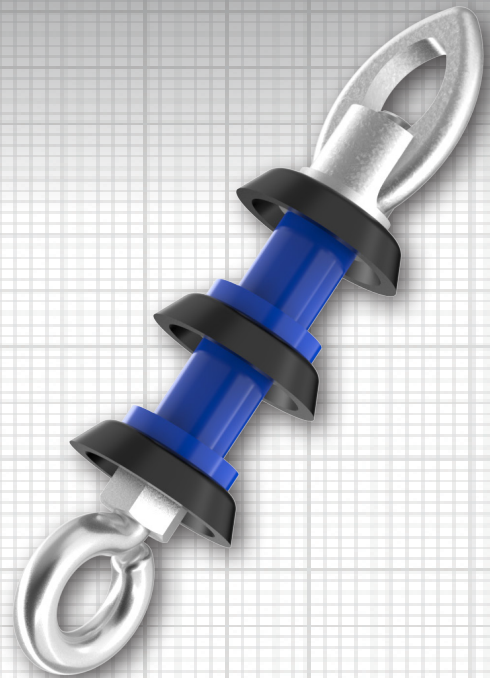

Innerduct Cup Projectile



Cal Missile duct projectiles are fast and efficient to run pull-lines

Used to pneumatically run pull lines through raceways, the Cal Missile™ duct projectiles are fast and efficient and are easily blown through out-of-round ducts. The Cal Missile features dual fastening rings, one on each end of the projectile, creating versatile mule-tape tie-points.

Cal Am's highly engineered polymer offers elasticity, toughness, and durability. Available with either two or three polyurethane cups, these cups are resistant to solvents, oxygen, ozone, and sunlight and have an outstanding flex-life guaranteed to outlast other line-carriers of their type on the market today.

HOW TO USE



1. Attach mule tape to the front of the Cal Missile at the stainless steel top loop

2. Run the length of the conduit with compressed air to clean out any debris prior to installing cable

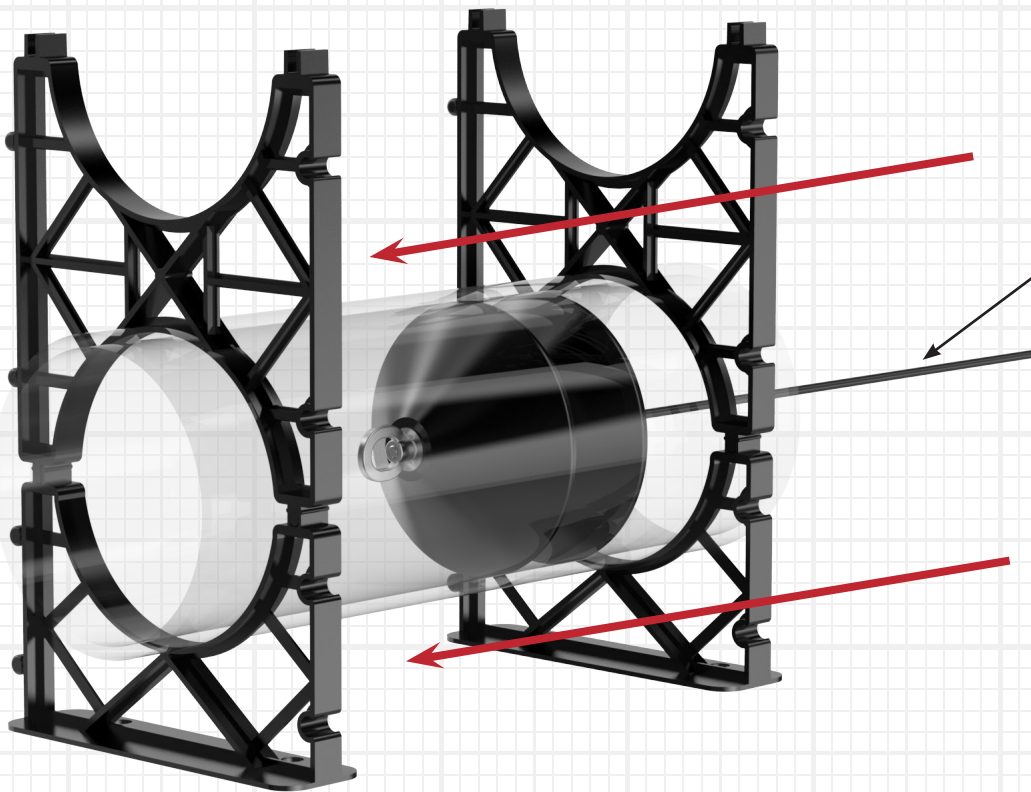
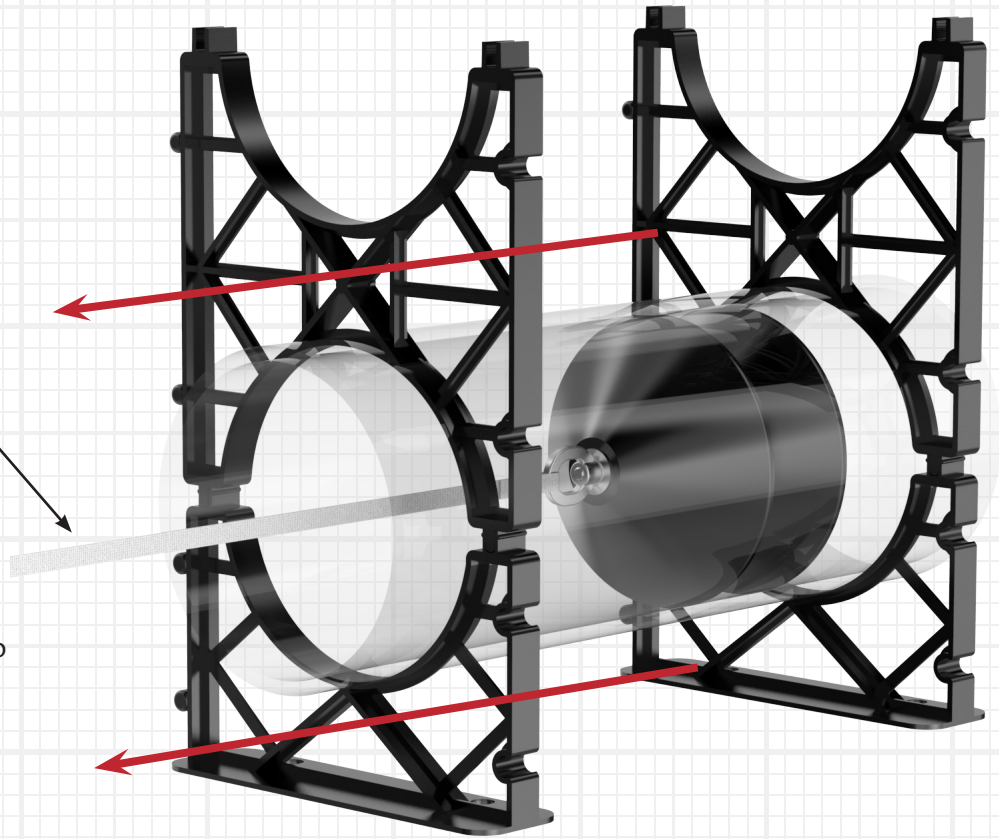

1. Attach a cable to the back of the Cal Missile™ at the stainless steel loop

2. Run the length of the conduit with compressed air for fast installation



Visit [CalAm.net](https://calam.net)

<https://calam.net/electrical-broadband/duct-projectiles/>

SPECIFICATIONS

PRODUCT NUMBER	EACH SIZE (IN)	EACH SIZE (mm)	UNIT OF MEASURE
DUCT CONE PROJECTILE			
2110-010	1.00	25	Each
2110-011*	1.25	32	Each
2110-012	1.25	32	Each
2110-013	1.375	35	Each
2110-014*	1.50	40	Each
2110-015	1.50	40	Each
2110-017	1.875	48	Each
2110-019*	2.00	50	Each
2110-020	2.00	50	Each
2110-025	2.50	65	Each
2110-030	3.00	80	Each
2110-040	4.00	100	Each
2110-050	5.00	125	Each
2110-060	6.00	150	Each
2110-080	8.00	200	Each
INNERDUCT CUP PROJECTILE			
2120-007	0.75	20	Each
2120-010	1.00	25	Each
2120-011	1.125	29	Each
2120-012	1.25	32	Each
2120-013	1.375	35	Each
2120-015	1.50	40	Each
2120-020	2.00	50	Each

* Specifically for SDR 11

For more technical information and/or to download the Tech Sheet for these products, please visit the Product Webpage: <https://calam.net/electrical-broadband/duct-projectiles/>

ABOUT CAL AM MANUFACTURING

Cal Am Manufacturing® specializes in products for use in underground electrical and broadband applications. Founded in Southern California over thirty-five years ago, Cal Am designs and produces fittings and sealing devices to serve utilities, municipalities, government facilities, data centers, and fiber optic projects, through a worldwide network of distributors.

TEST OUR PRODUCT

Learn more at: <https://calam.net/test-our-products>

Corporate Office:
El Cajon, CA 92020

Phone +1.619.336.9550
Fax +1.619.336.9549

sales@calam.net
marketing@calam.net
accounting@calam.net

www.CalAm.net